

Typical materials that can be degassed:

- RTV Silicone Rubber
- Araldite
- Polyester Resin
- Pastosals
- Casting Plaster
- Polysulphide Rubber
- Polyurethane Resin
- Adhesive Mixes
- Epoxy Resins
- Investment Plaster

Vacuum Degassing Overview:

When any of the above listed materials are mixed with the required additives, accelerators, filler etc., air bubbles can become trapped within the mixture. If not removed before the material cures the air bubbles can cause defects such as nodules, cavities and hollows in the finishes cast. With electrical and electronic encapsulation, these air bubbles can cause electrical breakdown. On intricate castings additional work will be required to correct the defects caused by the air bubbles.

All Epoxy Resins, Araldites, Silicone Rubbers as well as any other mixed materials to be degassed will expand during the degassing process. It is essential that a container of sufficient volume is used. It is not uncommon for materials to expand two to six times their initial volume while degassing. As the bubbles burst at the surface the expansion decreases. This process can take several minutes depending on the viscosity of the material, the speed of the vacuum pump and the volume of the vacuum chamber.

Consider the viscosity and the pot life of the materials. Materials with a very high viscosity may be very difficult to degas and will take a lot longer. If the pot life is short, then speed could be essential.

If you are unsure of the properties of your materials, then a few simple tests will help:

- Mix a small sample and without degassing see how long it remains fluid. That is essentially the pot life.
- Put a small sample in a container in the vacuum chamber and while closely observing through the lid see when the surface of the material starts to bubble. Use the vacuum isolation valve to stop pumping as soon as the first bubbles appear. Make a note of the pressure shown on the pressure gauge. Some materials will start to degas at quite high pressures – in excess of 50 mbar. Some materials will also seem to outgas for a very long time. This could be due to the pressure being too low and some of the volatiles in the material being evaporated off. The vacuum should only be held for a short period once bubbles are seen at the surface of the mixture, otherwise the chemical structure will be altered and curing time, so care should be taken with such materials to degas at a pressure which removes the air but does not start to evaporate the material or constituent parts of that material.

Once you are satisfied and confident the materials you are using are not going to cause problems then proceed.

Remove the vacuum chamber lid. Ensure that both the vent and vacuum isolation valves are closed and switch on the vacuum pump to warm up. A warm pump is more efficient and handles condensable vapours better.

Measure out the required amount of material together with any hardeners or fillers into a clean bucket of adequate size to allow for expansion. Mix well, either by hand or with an electric mixer.

Place the bucket in the vacuum chamber and replace the lid. Gently open the vacuum isolation valve. Some light hand pressure on the lid may be required to establish a good seal – you will see on the gauge when the pressure starts to fall indicating a seal has been made.

Technical Overview

Observe the surface of the material. Once bubbles start to come to the surface and break, close the vacuum isolation valve. If the bubbles subside after a short time open the valve again. Repeat that process so that you progressively pump the chamber down.

If there is a rapid rise in the level of the degassing material close the vacuum isolation valve and allow a little air back into the chamber with the vent valve. That will 'collapse' the degassing material and will break a lot of the surface air bubbles. Continue pumping down and by balancing both the vacuum isolation and vent valves it will be possible to degas quite volatile mixes.

Once you are satisfied the material has been degassed close the vacuum isolation valve, open the vent valve and remove the chamber lid. You are now ready to use your degassed material.

This degassed mixture is then poured into the mould taking care to minimise any trapped air. When the mould has been filled it can be placed into the vacuum chamber and evacuated as before. This time there should be minimum air bubbles breaking the surface which were trapped in undercuts or from the surface of the mould. Please again beware of boiling off the volatile components of the mixture, only a few seconds should be required at full vacuum.

A few important things:

- **NEVER** allow degassing material to top the container you are using.
- **NEVER** allow any acetone-based solvents to be in contact with the chamber lid. The lid can be damaged or destroyed by such solvents.
- **ALWAYS** use either a disposable or a cleanable container within the chamber.
- **ALWAYS** check both the level of oil in the vacuum pump and the condition of that oil. If the oil is particularly cloudy it is time for an oil change. Degassing processes are quite hard on vacuum pumps so change the oil regularly. Oil is a lot cheaper than a pump service, or a replacement pump! When changing the oil, make sure the pump is hot before draining and NEVER use solvents of any kind as a flushing agent. If you need to flush the pump, use only clean vacuum pump oil.

Common Causes of Bubbles in Castings:

- Air trapped in moulds.
- Volatile components in the mixture rising to the surface when under vacuum.
- Air from mixing of resins and hardeners.
- Gases generated from the curing process.
- Solvent vapours from cleaning or certain mould release agents.
- Moisture or contamination in the mixture.

Factors That Affect the Removal of Gases:

- High viscosity.
- Heating the material can help reduce the high viscose materials, but consideration should be given to the effect on the pot life before heating any mixed materials.
- Larger, faster vacuum pumps.
- Ultimate final vacuum pump pressure.
- Stirring under vacuum.
- Volume of mixture being degassed.

DP9 and DP9 Kits,

Technical Data Sheet

System Overview

The DP9 is a 9-litre powder coated mild steel vacuum chamber with a welded construction. It features an acrylic lid and front facing 1/4" BSP manifold. The manifold has a brass hose nozzle for connecting a 1/2" bore hose.

Our DP chambers are compliant with ASTM D3078- 02 and ISO 20484 testing standards, they are pressure tested to 1×10^{-2} mbar and helium leak tested.

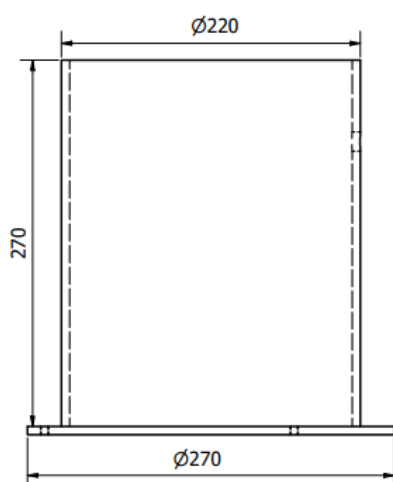

Our Full Degassing Pot Range



Model	Volume (Litres)	Internal Dimensions $\varnothing \times H$ (mm)
DP9	9	206 x 270
DP27	27	311 x 356
DP42	42	373 x 381
DP76	76	460 x 460
DP118	118	500 x 600
DP250	250	600 x 900



Specifications

- Internal Dimensions: 206mm \varnothing x 270mm H
- Capacity - 9 Litres
- Weight - Approximately 12kg
- Material – Powder coated mild steel
- Sealing Face – Nitrile L Gasket
- Clear cast acrylic lids
- AVE 63mm glycerine filled indication gauge
- Vacuum isolation valve and air admittance ball valve with pneumatic silencer

Options/Extras

- AVE Lid Mounted Stirrer (0-133 or 0-200 RPM)
- 0 – 180°C Heater Platform
- Electrical vacuum feedthroughs
- Additional KF or BSP ports
- IRV20 vacuum regulator (Max flow 240L/min)
- Traceable or UCAS gauge calibration
- Upgrade to a stainless-steel pot and fittings

DP9 Vacuum Kits

If you require a complete system, our DP vacuum kits are an excellent option. When sold as a kit we offer a 10% discount on all DVP pumps. Our DP kits come complete with; a vacuum chamber, a vacuum pump, a vacuum manifold and 2 meters of vacuum hose.

MODEL	VACUUM PUMP	NOMINAL CAPACITY (M ³ /H)	EVACUATION TIME*
DP9K4	DVP LC.4	4	00:50
DP9K8	DVP LC.8	8	00:25

* The evacuation time has been calculated assuming a clean and empty chamber. This is the approximate Min:Sec it will take for the chamber to be evacuated from atmospheric conditions to 2mbar.

DP27 and DP27 Kits,

Technical Data Sheet

System Overview

The DP27 is a 27-litre powder coated mild steel vacuum chamber with a welded construction. It features an acrylic lid and front facing 1/2" BSP manifold and an additional 1/2" BSPP accessory port in the rear. The manifold has a brass hose nozzle for connecting a 1/2" bore hose.

Our DP chambers are compliant with ASTM D3078- 02 and ISO 20484 testing standards, they are pressure tested to 1×10^{-2} mbar and helium leak tested.

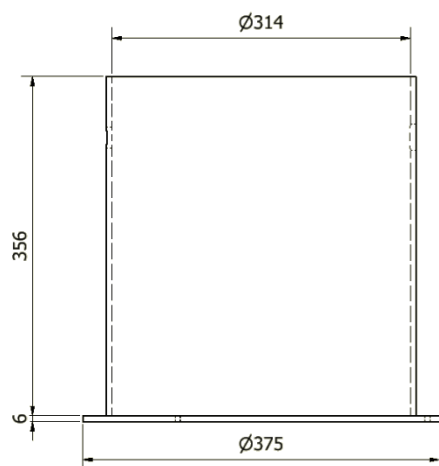

Our Full Degassing Pot Range



Model	Volume (Litres)	Internal Dimensions Ø x H (mm)
DP9	9	206 x 270
DP27	27	311 x 356
DP42	42	373 x 381
DP76	76	460 x 460
DP118	118	500 x 600
DP250	250	600 x 900



Specifications

- Internal Dimensions: 311mm Ø x 356mm H
- Capacity - 27 Litres
- Weight - Approximately 22kg
- Material – Powder coated mild steel
- Sealing Face – Nitrile L Gasket
- Clear cast acrylic lids
- AVE 63mm glycerine filled indication gauge
- Vacuum isolation valve and air admittance ball valve with pneumatic silencer

Options/Extras

- AVE Lid Mounted Stirrer (0-133 or 0-200 RPM)
- 0 – 180°C Heater Platform
- Electrical vacuum feedthroughs
- Additional KF or BSP ports
- IRV20 vacuum regulator (Max flow 240L/min)
- Traceable or UCAS gauge calibration
- Upgrade to a stainless-steel pot and fittings

DP27 Vacuum Kits

If you require a complete system, our DP vacuum kits are an excellent option. When sold as a kit we offer a 10% discount on all DVP pumps. Our DP kits come complete with; a vacuum chamber, a vacuum pump, a vacuum manifold and 2 meters of vacuum hose.

MODEL	VACUUM PUMP	NOMINAL CAPACITY (M ³ /H)	EVACUATION TIME*
DP27K8	DVP LC.8	8	1:16
DP27K12	DVP LC.12	12	0:50

* The evacuation time has been calculated assuming a clean and empty chamber. This is the approximate Min:Sec it will take for the chamber to be evacuated from atmospheric conditions to 2mbar.

DP42 and DP42 Kits,

Technical Data Sheet

System Overview

The DP42 is a 42-litre powder coated mild steel vacuum chamber with a welded construction. It features an acrylic lid and front facing 1/2" BSP manifold. The manifold has a brass hose nozzle for connecting a 1/2" bore hose. An additional 1/2" BSP auxiliary port is located on the rear.

Our DP chambers are compliant with ASTM D3078- 02 and ISO 20484 testing standards, they are pressure tested to 1×10^{-2} mbar and helium leak tested.

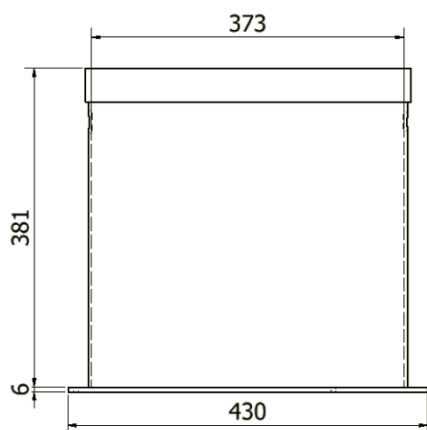

Our Full Degassing Pot Range



Model	Volume (Litres)	Internal Dimensions Ø x H (mm)
DP9	9	206 x 270
DP27	27	311 x 356
DP42	42	373 x 381
DP76	76	460 x 460
DP118	118	500 x 600
DP250	250	600 x 900



Specifications

- Internal Dimensions: 373mm Ø x 381mm H
- Capacity - 42 Litres
- Weight - Approximately 23kg
- Material – Powder coated mild steel
- Sealing Face – Nitrile L gasket
- Clear cast acrylic lid
- AVE 63mm glycerine filled indication gauge
- Vacuum isolation valve and air admittance ball valve with pneumatic silencer

Options/Extras

- AVE lid mounted stirrer (0-133 or 0-200 RPM)
- 0 – 180°C heater platform
- Electrical vacuum feedthroughs
- Additional KF or BSPP ports
- IRV20 vacuum regulator (max flow 240L/min)
- Traceable or UCAS gauge calibration
- Upgrade to a stainless-steel pot and fittings

DP42 Vacuum Kits

If you require a complete system, our DP vacuum kits are an excellent option. When sold as a kit we offer a 10% discount on all DVP pumps. Our DP kits come complete with; a vacuum chamber, a vacuum pump, a vacuum manifold and 2 meters of vacuum hose.

MODEL	VACUUM PUMP	NOMINAL CAPACITY (M ³ /H)	EVACUATION TIME*
DP42K12	DVP LC.12	12	2:22
DP42K25	DVP LC.25	25	1:08

* The evacuation time has been calculated assuming a clean and empty chamber. This is the approximate Min:Sec it will take for the chamber to be evacuated from atmospheric conditions to 2mbar.

DP76 and DP76 Kits,

Technical Data Sheet

System Overview

The DP76 is a 76-litre powder coated mild steel vacuum chamber with a welded construction. It features an acrylic lid and front facing 3/4" BSP manifold. The manifold has a brass hose nozzle for connecting a 1/2" bore hose. An additional 3/4" BSP auxiliary port is located on the rear.

Our DP chambers are compliant with ASTM D3078- 02 and ISO 20484 testing standards, they are pressure tested to 1×10^{-2} mbar and helium leak tested.

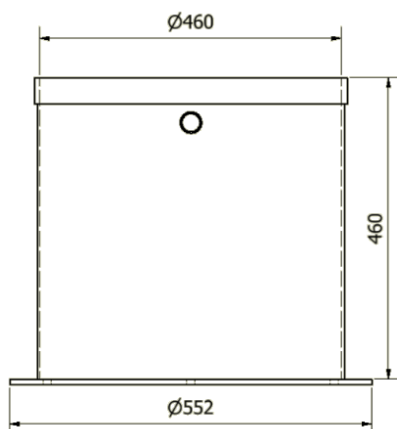

Our Full Degassing Pot Range



Model	Volume (Litres)	Internal Dimensions $\varnothing \times H$ (mm)
DP9	9	206 x 270
DP27	27	311 x 356
DP42	42	373 x 381
DP76	76	460 x 460
DP118	118	500 x 600
DP250	250	600 x 900



Specifications

- Internal Dimensions: 460mm \varnothing x 460mm H
- Capacity - 76 Litres
- Weight - Approximately 47kg
- Material – Powder coated mild steel
- Sealing Face – Nitrile L gasket
- Clear cast acrylic lid
- AVE 63mm glycerine filled indication gauge
- Vacuum isolation valve and air admittance ball valve with pneumatic silencer

Options/Extras

- AVE lid mounted stirrer (0-133 or 0-200 RPM)
- 0 – 180°C heater platform
- Electrical vacuum feedthroughs
- Additional KF or BSPP ports
- IRV20 vacuum regulator (max flow 240L/min)
- Traceable or UCAS gauge calibration
- Upgrade to a stainless-steel pot and fittings

DP76 Vacuum Kits

If you require a complete system, our DP vacuum kits are an excellent option. When sold as a kit we offer a 10% discount on all DVP pumps. Our DP kits come complete with; a vacuum chamber, a vacuum pump, a vacuum manifold and 2 meters of vacuum hose.

Model	Vacuum Pump	Nominal Capacity (m^3/h)	Evacuation Time*
DP76K25	DVP LC.25	25	01:08
DP76K60	DVP LC.60	60	00:28

* The evacuation time has been calculated assuming a clean and empty chamber. This is the approximate Min:Sec it will take for the chamber to be evacuated from atmospheric conditions to 2mbar.

System Overview

The DP118 is a 118-litre powder coated mild steel vacuum chamber with a welded construction. It features an acrylic lid and front facing 3/4" BSP manifold. The manifold has a brass hose nozzle for connecting a 1/2" bore hose. An additional 3/4" BSP auxiliary port is located on the rear.

Our DP chambers are compliant with ASTM D3078- 02 and ISO 20484 testing standards, they are pressure tested to 1x10⁻²mbar and helium leak tested.

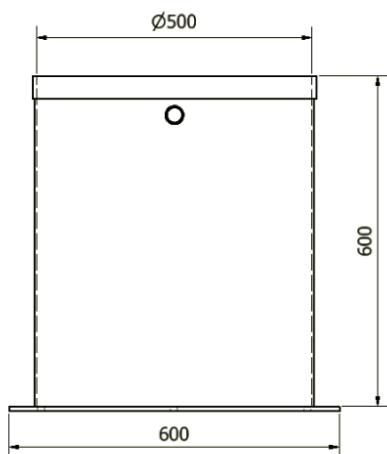

Our Full Degassing Pot Range



Model	Volume (Litres)	Internal Dimensions Ø x H (mm)
DP9	9	206 x 270
DP27	27	311 x 356
DP42	42	373 x 381
DP76	76	460 x 460
DP118	118	500 x 600
DP250	250	600 x 900



Specifications

- Internal Dimensions: 500mm Ø x 600mm H
- Capacity - 118 Litres
- Weight - Approximately 57kg
- Material – Powder coated mild steel
- Sealing Face – Nitrile L gasket
- Clear cast acrylic lid
- AVE 63mm glycerine filled indication gauge
- Vacuum isolation valve and air admittance ball valve with pneumatic silencer

Options/Extras

- AVE lid mounted stirrer (0-133 or 0-200 RPM)
- 0 – 180°C heater platform
- Electrical vacuum feedthroughs
- Additional KF or BSPP ports
- IRV20 vacuum regulator (max flow 240L/min)
- Traceable or UCAS gauge calibration
- Upgrade to a stainless-steel pot and fittings

DP118 Vacuum Kits

If you require a complete system, our DP vacuum kits are an excellent option. When sold as a kit we offer a 10% discount on all DVP pumps. Our DP kits come complete with; a vacuum chamber, a vacuum pump, a vacuum manifold and 2 meters of vacuum hose.

MODEL	VACUUM PUMP	NOMINAL CAPACITY (M ³ /H)	EVACUATION TIME*
DP118K25	DVP LC.25	25	1:58
DP118K60	DVP LC.60	60	0:49

* The evacuation time has been calculated assuming a clean and empty chamber. This is the approximate Min:Sec it will take for the chamber to be evacuated from atmospheric conditions to 1mbar.