

## DP42 and DP42 Kits,

### Technical Data Sheet

### System Overview

The DP42 is a 42-litre powder coated mild steel vacuum chamber with a welded construction. It features an acrylic lid and front facing 1/2" BSP manifold. The manifold has a brass hose nozzle for connecting a 1/2" bore hose. An additional 1/2" BSP auxiliary port is located on the rear.

Our DP chambers are compliant with ASTM D3078- 02 and ISO 20484 testing standards, they are pressure tested to  $1 \times 10^{-2}$  mbar and helium leak tested.

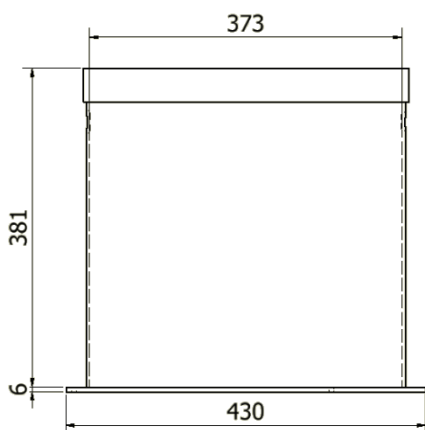

### Our Full Degassing Pot Range



Model	Volume (Litres)	Internal Dimensions Ø x H (mm)
DP9	9	206 x 270
DP27	27	311 x 356
DP42	42	373 x 381
DP76	76	460 x 460
DP118	118	500 x 600
DP250	250	600 x 900



### Specifications

- Internal Dimensions: 373mm Ø x 381mm H
- Capacity - 42 Litres
- Weight - Approximately 23kg
- Material – Powder coated mild steel
- Sealing Face – Nitrile L gasket
- Clear cast acrylic lid
- AVE 63mm glycerine filled indication gauge
- Vacuum isolation valve and air admittance ball valve with pneumatic silencer

### Options/Extras

- AVE lid mounted stirrer (0-133 or 0-200 RPM)
- 0 – 180°C heater platform
- Electrical vacuum feedthroughs
- Additional KF or BSPP ports
- IRV20 vacuum regulator (max flow 240L/min)
- Traceable or UCAS gauge calibration
- Upgrade to a stainless-steel pot and fittings

### DP42 Vacuum Kits

If you require a complete system, our DP vacuum kits are an excellent option. When sold as a kit we offer a 10% discount on all DVP pumps. Our DP kits come complete with; a vacuum chamber, a vacuum pump, a vacuum manifold and 2 meters of vacuum hose.

MODEL	VACUUM PUMP	NOMINAL CAPACITY (M <sup>3</sup> /H)	EVACUATION TIME*
DP42K12	DVP LC.12	12	2:22
DP42K25	DVP LC.25	25	1:08

\* The evacuation time has been calculated assuming a clean and empty chamber. This is the approximate Min:Sec it will take for the chamber to be evacuated from atmospheric conditions to 2mbar.