

ACB96-PT,

Technical Data Sheet

System Overview

The ACB 96-PT is our 96 litre, clear cast acrylic package testing, vacuum chamber. All chambers within our PT range are designed specifically to determine leaks in flexible packaging via bubble leak submersion testing.

Our ACB chambers are compliant with ASTM D3078-02 and ISO 20484 testing standards. To ensure quality, all clear cast acrylic chambers are tested to their vacuum limit of 5×10^{-2} mbar.

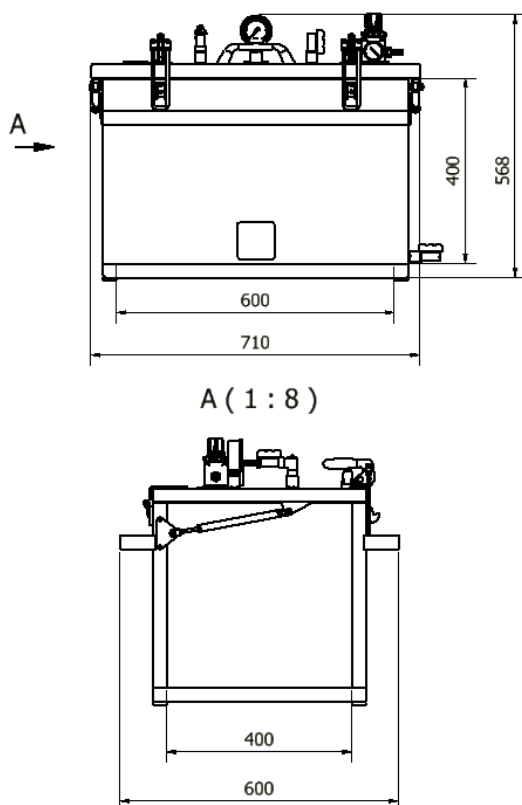

Our Full Package Testing Range

MODEL	INTERNAL DIMENSIONS W x D x H (MM)
ACB16-PT	360 x 260 x 170
ACB21-PT	500 x 250 x 170
ACB27-PT	300 x 300 x 300
ACB64-PT	400 x 400 x 400
ACB72-PT	450 x 400 x 400
ACB96-PT	600 x 400 x 400



Specifications

- Internal Dimensions: 600mm (W) x 400mm (D) x 400mm (H)
- Capacity - 96 Litres
- Weight - Approximately 78kg
- Material – Clear cast acrylic
- Sealing Face – 8mm silicone 'O' ring cord

Features

- Clear perforated acrylic submerge plate, suspended with stainless steel threaded studs for easy height adjustment.
- ¼" BSPB drain valve.
- 63mm glycerine filled vacuum indication gauge.
- ¼" BSPB air admittance ball valve.
- ¼" BSPB vacuum isolation valve.
- Lid mounted adjustable vacuum regulator, 240 ltr/min maximum flow.
- Over-centre latches to ensure lid seal.

ACB96-PT K25 Vacuum Kit

The ACB96-PT K25 vacuum kit offers a complete solution for bubble leak submersion package testing. Include within this kit is the ACB96-PT, a DVP LC.25 vacuum pump and all the necessary fittings for a plug and play set up.

Custom design Service

All chambers may be customised to meet specific requirements through our custom design service. Bespoke options may include personalised dimensions, additional inlet ports and electrical vacuum feedthroughs.