

ACB21-PT,

Technical Data Sheet

System Overview

The ACB 21-PT is our 21 litre, clear cast acrylic package testing, vacuum chamber. All chambers within our PT range are designed specifically to determine leaks in flexible packaging via bubble leak submersion testing.

Our ACB chambers are compliant with ASTM D3078-02 and ISO 20484 testing standards. To ensure quality, all clear cast acrylic chambers are tested to their vacuum limit of 5×10^{-2} mbar.

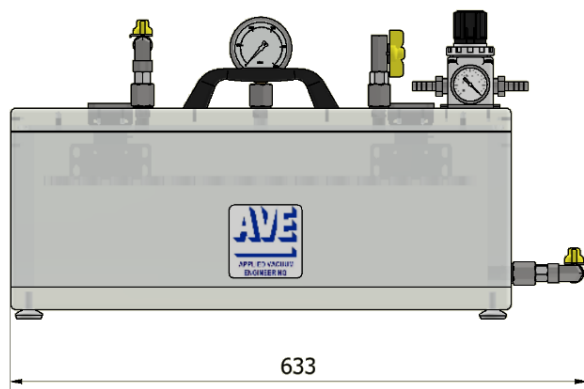
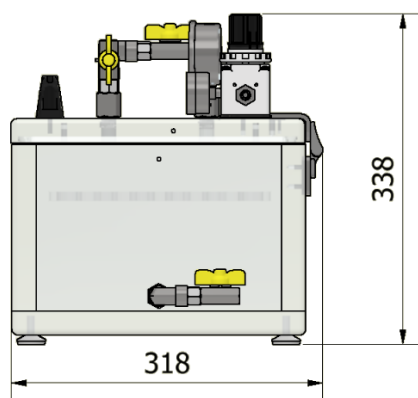

Our Full Package Testing Range

| MODEL | INTERNAL DIMENSIONS W x D x H (MM) |
|----------|---------------------------------------|
| ACB16-PT | 360 x 260 x 170 |
| ACB21-PT | 500 x 250 x 170 |
| ACB27-PT | 300 x 300 x 300 |
| ACB64-PT | 400 x 400 x 400 |
| ACB72-PT | 450 x 400 x 400 |
| ACB96-PT | 600 x 400 x 400 |

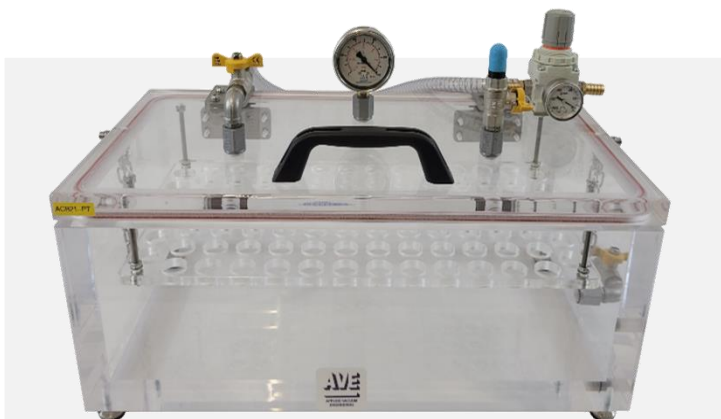

Specifications

- Internal Dimensions: 500mm (W) x 250mm (D) x 170mm (H)
- Capacity - 21 Litres
- Weight - Approximately 22kg
- Material – Clear cast acrylic
- Sealing Face – 8mm silicone 'O' ring cord

Features

- Clear perforated acrylic submerge plate, suspended with stainless steel threaded studs for easy height adjustment.
- ¼" BSPP drain valve.
- 63mm glycerine filled vacuum indication gauge.
- ¼" BSPP air admittance ball valve.
- ¼" BSPP vacuum isolation valve.
- Lid mounted adjustable vacuum regulator, 240 ltr/min maximum flow.
- Over-centre latches to ensure lid seal.

ACB21-PT K8 Vacuum Kit

The ACB21-PT K8 vacuum kit offers a complete solution for bubble leak submersion package testing. Include within this kit is the ACB21-PT, a DVP LC.8 vacuum pump and all the necessary fittings for a plug and play set up.

Custom design Service

All chambers may be customised to meet specific requirements through our custom design service. Bespoke options may include personalised dimensions, additional inlet ports and electrical vacuum feedthroughs.